

UVA 600-ST Series

Intermittent Motion Packaging Machine



Packaging Solutions and Technology

UVA 600-ST series



Large Format Bags

- ▶ Pillow up to 25 kg
- ▶ Bag length up to 790 mm
- ▶ Bag width up to 600 mm

World Service Program

- ▶ 24/7 technical support
- ▶ Service contract including maintenance

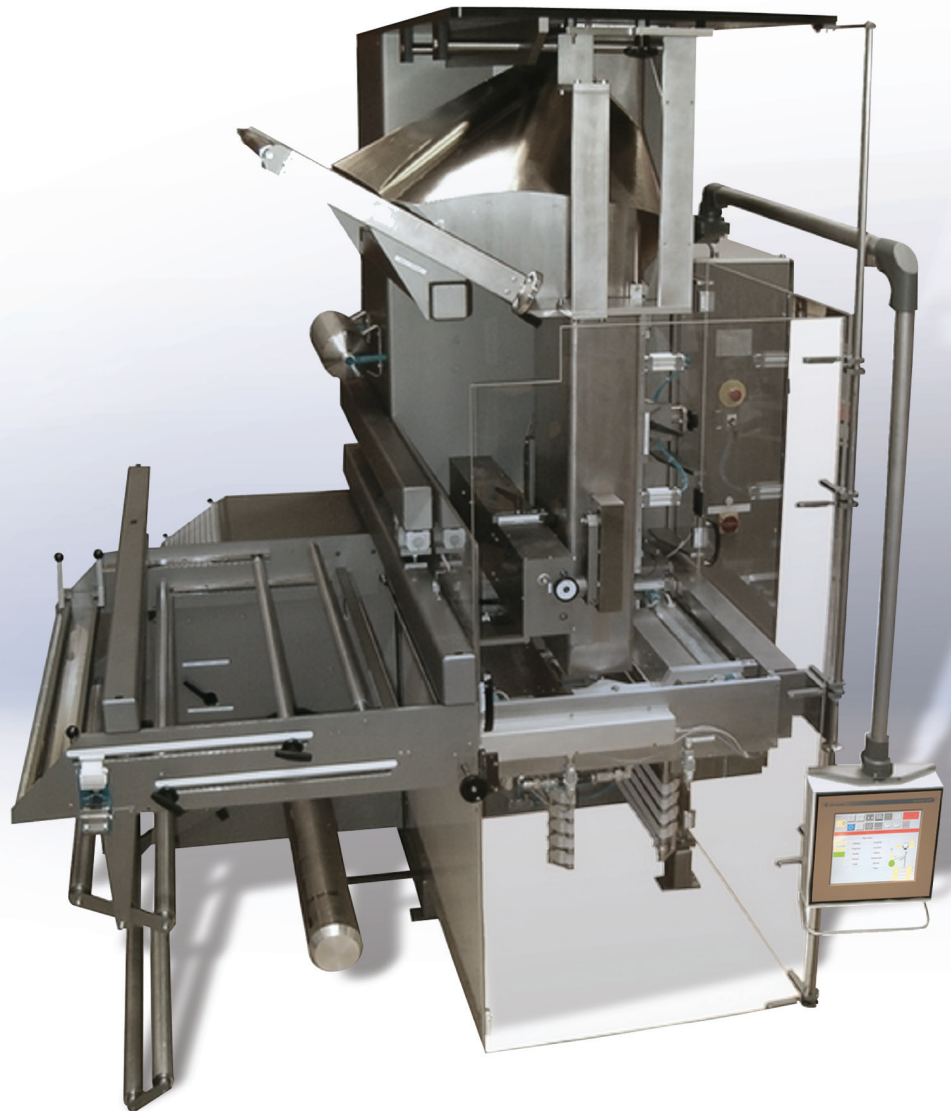

Contact Details

Head Office • PMB-UVA International B.V.

T +31 (0)40 282 5000 • F +31 (0)40 282 5001 • Meerenakkerweg 32 • 5652 AV Eindhoven • The Netherlands • sales@uva-packaging.com • www.uva-packaging.com

Northern American Division • UVA Packaging

T +1-804 275 8067 • F +1-804 271 3096 • 8111 Virginia Pine Ct. • Richmond, Virginia 23237 • United States of America • info@pmb-uvainc.com • www.pmb-uvainc.com

Detailed Machine Specifications



UVA 600-ST series

Machine Design

- ▶ Easy floor clean up due to unique design and concept
- ▶ Closed housing, vibration free machine design
- ▶ Maintenance friendly design with less wear and tear parts
- ▶ Machine guard in sturdy transparent Plexiglas

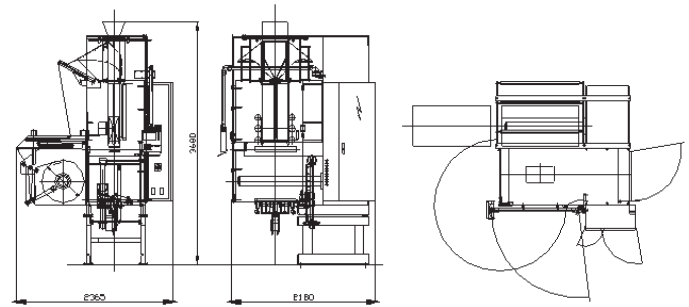

Controls

- ▶ Double Servo motor for cross seal
- ▶ Touch screen for production information and fault display
- ▶ 200 production program memory for quick changeovers
- ▶ Servo on draw off belt
- ▶ Slip compensation for film transport through film encoder
- ▶ Continuous motion power film reel unwind motor; controlled by dancer unit

Efficiency Management

- ▶ Efficiency Statistics monitor with "reason code" interface
- ▶ Drop time adjustment on screen
- ▶ Production counter with reset button at control panel
- ▶ Pressure sensor for low air pressure detection with machine stop
- ▶ Program selectable cross jaw opening for maximum output with different bag sizes
- ▶ Film reel carrier adjustable for instant web track correction
- ▶ Film reel limit detector with machine stop before end of reel
- ▶ Electronic temperature control for front, rear and long seal jaws

Ease of Use

- ▶ Vertical seal bar for long seals
- ▶ Automatic vertical seal bar retraction by machine stop to avoid heat build up at tube
- ▶ Temperature controllers with precise, separate control for front, rear and long seal jaws
- ▶ Film reel for easy roll change (expansion shaft), Self centering and positioning

After Sales Service

- ▶ Low cost on maintenance, uptime guaranteed
- ▶ Global and service network contract possibilities

Machine Specification

UVA 600-ST

Technology	Intermittent Motion
Bag width	200-600 mm
Bag width, block bottom	140-400 mm
Front to back, block bottom	50-200 mm
Bag length	790 mm
Power consumption	15 kVA
Air requirements	6 bar
Maximum film roll width	1240 mm
Maximum film reel diameter (D)	685 mm
Core diameter	150 mm
Maximum machine output	60 bags/min.
Machine weight approximately	2000 kg
Dimensions (stand.) HxWxL in mm	2620x2180x2365

Bag Styles

max. Speed

Pillow	✓ 60 bpm
Block Bottom	✓ 45 bpm
Gusseted	✓ 45 bpm
Corner Crease	✓ 45 bpm
Multi-bag	✓ 45 bpm

Ease of Use

Easy opening	✓
Slider zipper	✓
P2C zipper	✓
Carry handle	✓